

Ultrasonic Early Kick Detection (EKD) System

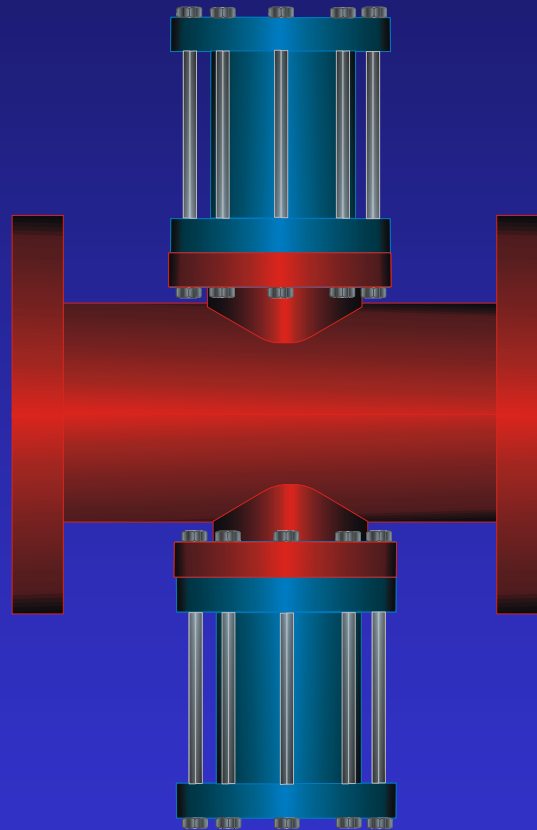

EKD System-Principle & Properties

Principle: The sound any change in the speed of sound is measurement in real time.

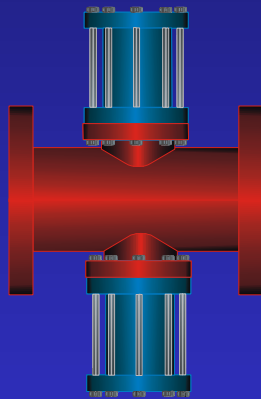

Properties: -For all drilling muds suited
-No limitation by cuttings and weight
-For all flange sizes and standards

Enhancements: - Acoustic Attenuation Spectroscope
- Solids & Cutting Separator control
- Mud Flow Meter

Ultrasonic Early Kick Detection (EKD) System

Mechanical limits

Standard minimal flange sizes: 3 Zoll

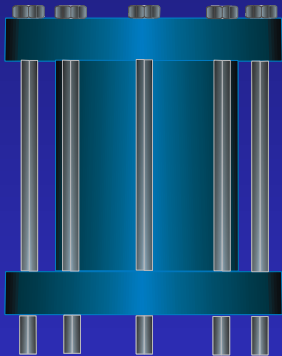

Sensor basic modul for all flange sizes

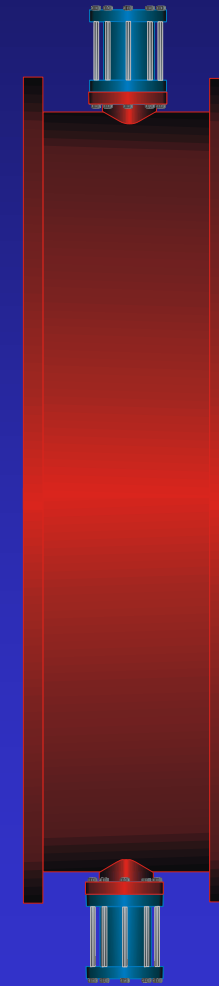
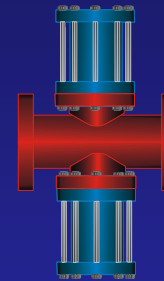

Maximum distance between sensor basic modules: 40 Zoll

Ultrasonic Early Kick Detection (EKD) System

Specifications I

Applicability: Any mud liquids mix including entrained gas and solids (cuttings)

Operating Temperature: Sensor - 40°C +150°C
 Unit - 40°C +85°C

Operating Density: 0 – 25.5 PPG

Spool Sizes & Material: Available in various spool sizes and materials
 as required

minimal 3 Zoll flange sizes, maximal distance
between basic sensor modules 40 Zoll
unit housing aluminium

Ultrasonic Early Kick Detection (EKD) System

Specifications II

Measurement & Ranges

	Units	Range
Sonic speed	m/s	300 – 10000
Resolution	m/s	0.02
Standard deviation	ps	>50

Mud Types	Oil based mud Water based mud Syntetic mud
-----------	--

Response Time	real time measurements (data updatet every 0.1 seonds)
---------------	--

Output Signals	RS485 Modbus Current & voltage loops Specific signals for AAS application
----------------	--

Ultrasonic Early Kick Detection (EKD) System

Specifications III

Ingress Protection (IP) rating

Transmitter

IP-67

Sensor

IP-68

Power requirements

18 to 35 V DC, 0.2 A

Methods of protection

Flameproof (d) and encapsulation (m)

Gas groups

IIB and IIA; US/Can Groups C

Flammable substance

G, D

Hazardous area classification

ATEX: Zone 0, Zone 1

II2G Ex d IIC Gb

II2D Ex t IIIC Db

IECEX:

Ex d IIC Gb

Ex t IIIC Db

US: Class I, Division 1, Groups A, B, C

Class II, Division 1, Groups E, F, G

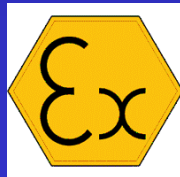

IBJ Technology

Ingenieurbüro Jäger

EKD in the mud line – basic configuration

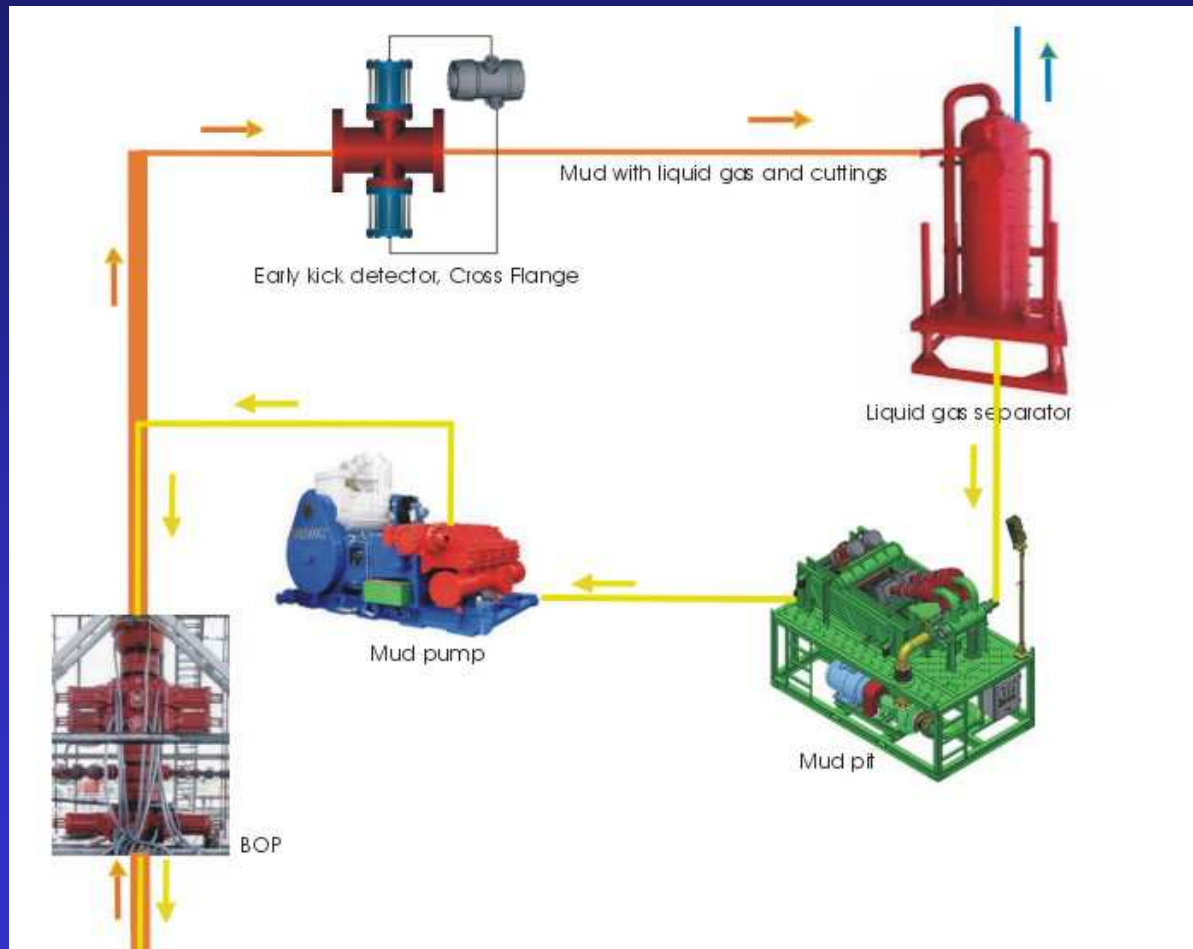

Basic configuration in the mud return line.

EKD in the mud line – basic & AAS

An option of the EKD system is the application of Acoustic Attenuation Spectroscopy (AAS).

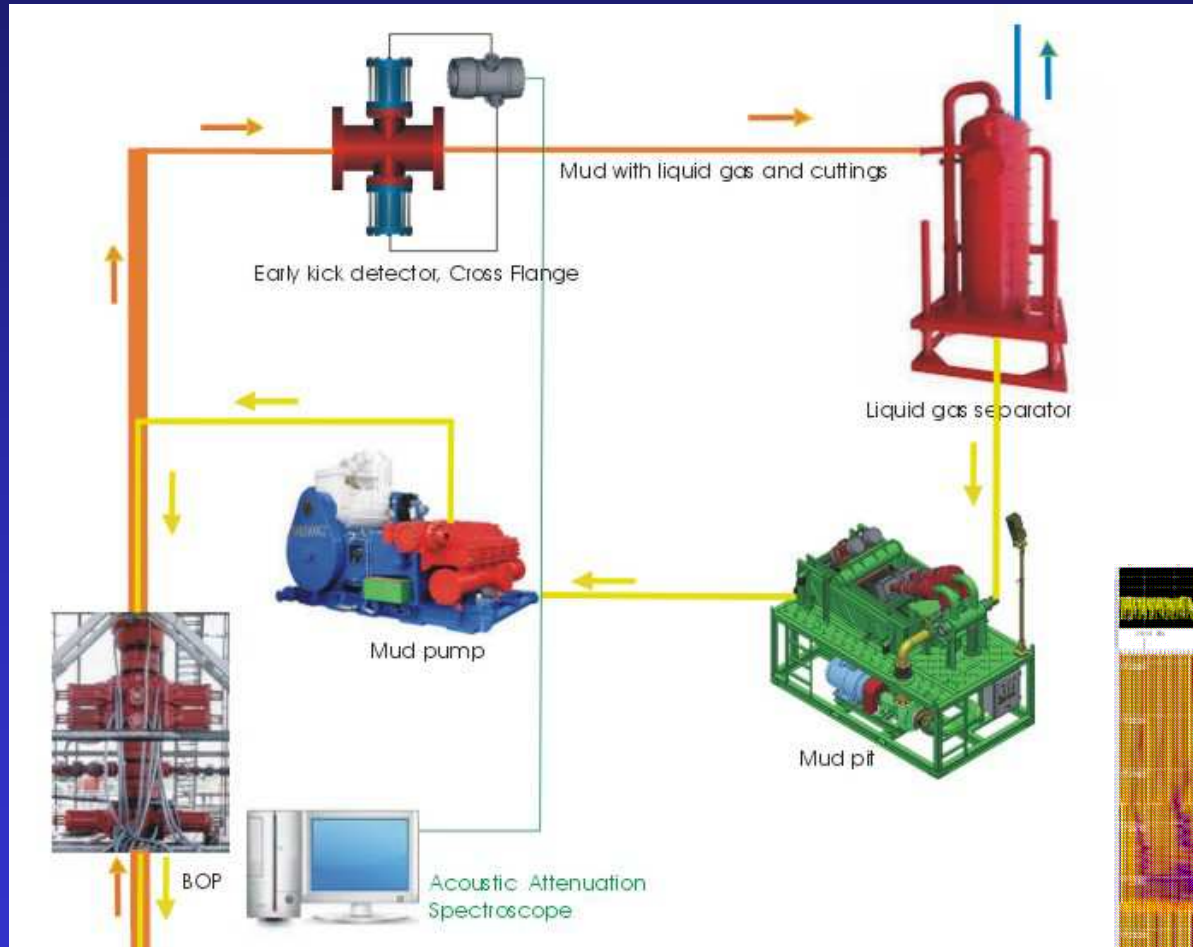

By disperse system of Mud can multiphase proportions of dissolved and gaseous hydrocarbons are immediately detected at very low concentrations. The resolution is unsurpassed.

Benefits:

- minimal Cost for Hardware Option
- GUI for PC and SCADA Systems

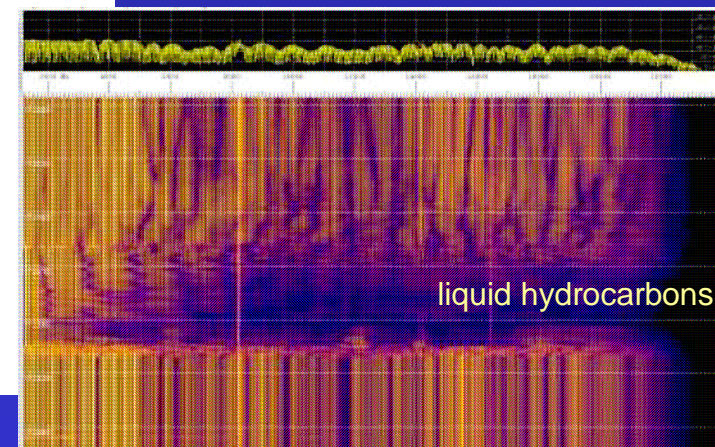

AAS real-time sonic log

EKD in the mud line – enhancement I

Solid and Cutting Separator Control Unit

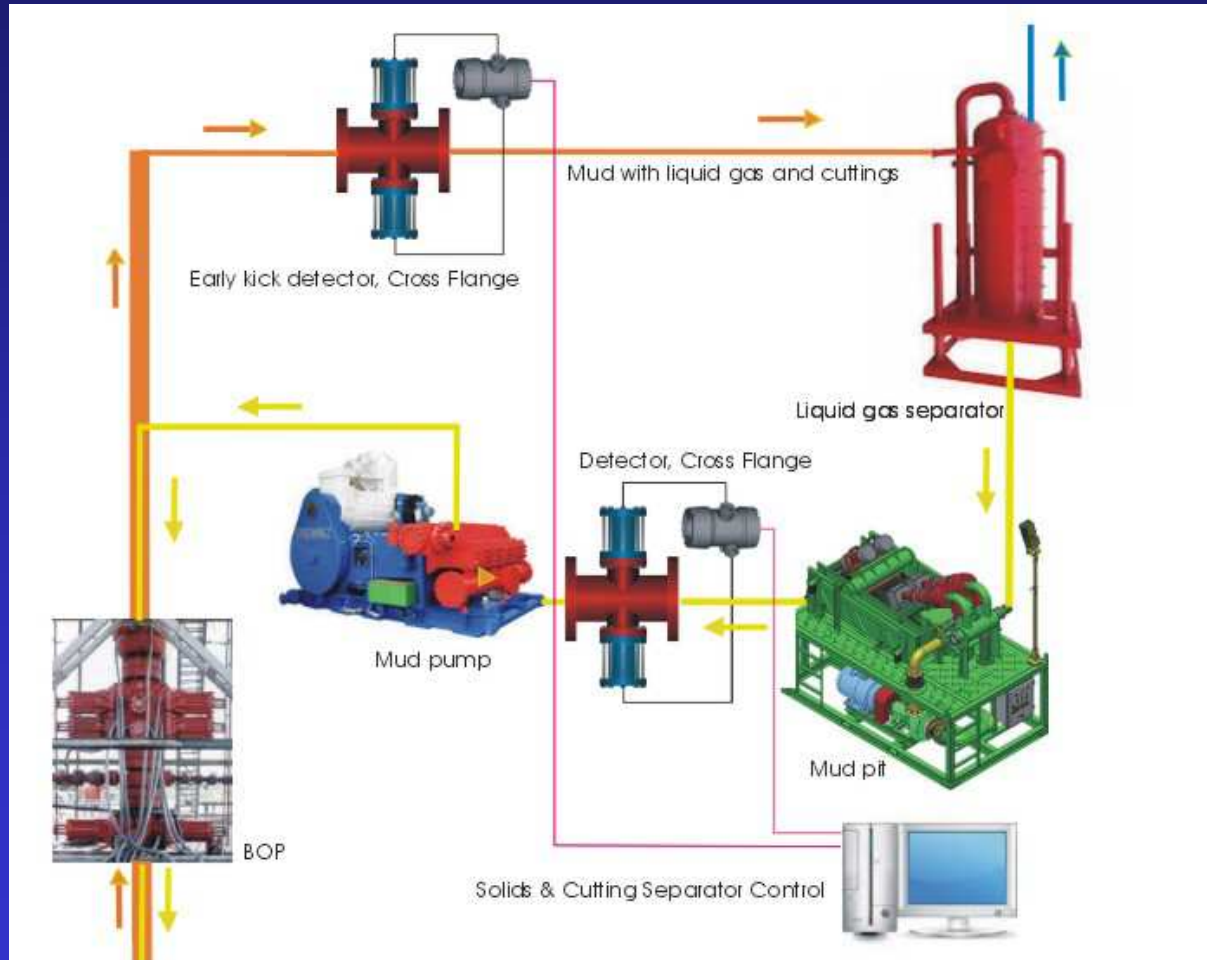

Drilling fluid maintenance cost, clean up & disposal cost as well as the overall cost of boring, can be reduced dramatically when proper solids control techniques are utilized.

Several ultrasonic parameters are compared time range in a given in realtime. In case of differences that a defined predetermined range are larger can intervene in the process.

In large plants are several Detectors to be installed between the treatment stages.

Benefit:

- low cost version for lower pressure levels
- same Detectors

EKD in the mud line – enhancement II

Solid and Cutting Separator Control Unit & AAS

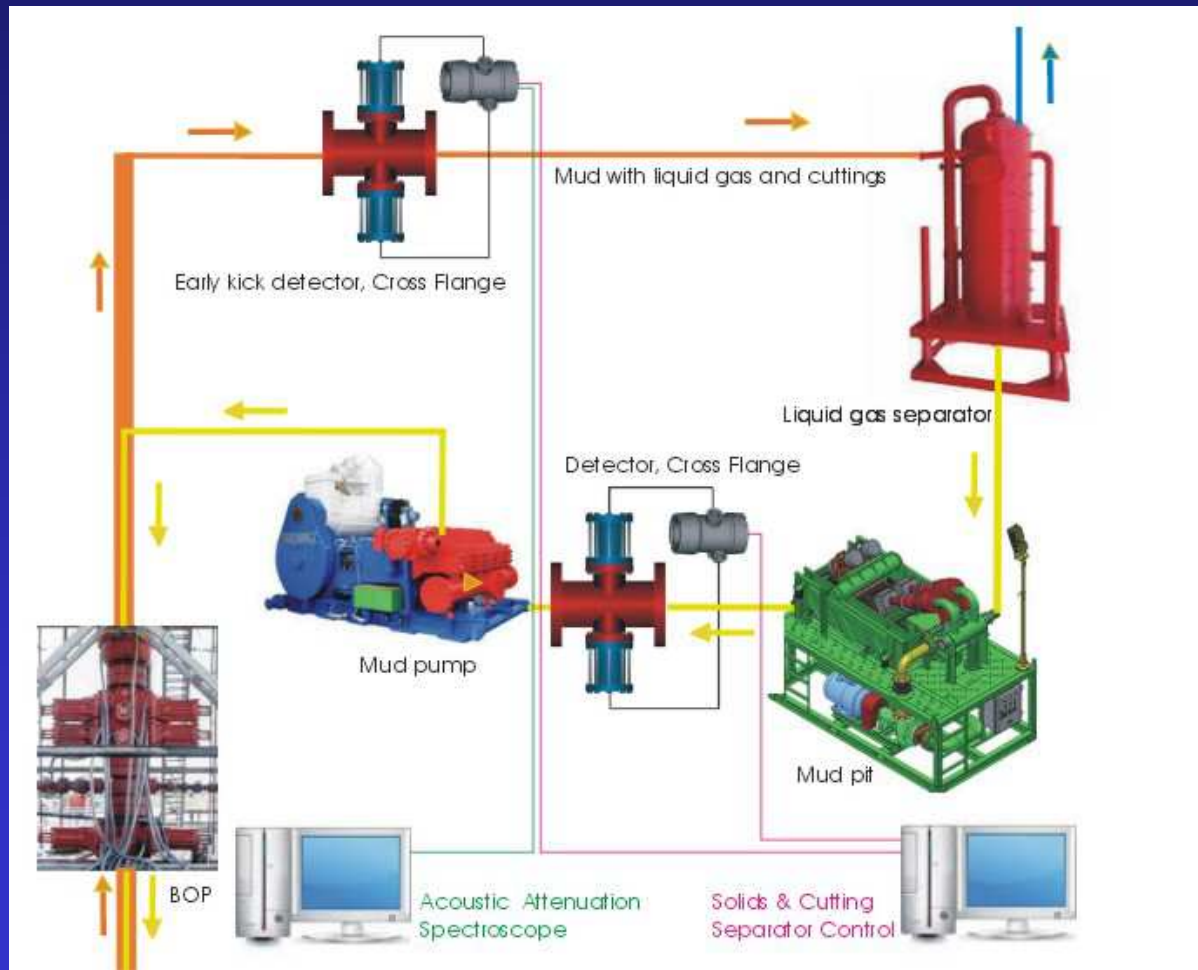

Solids & Cutting Separator Control Measurement

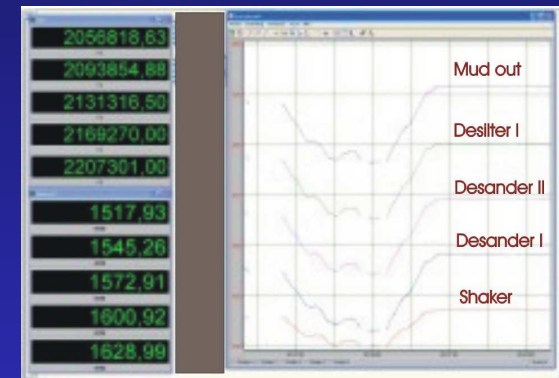

Acoustic Attenuation Spectroscope

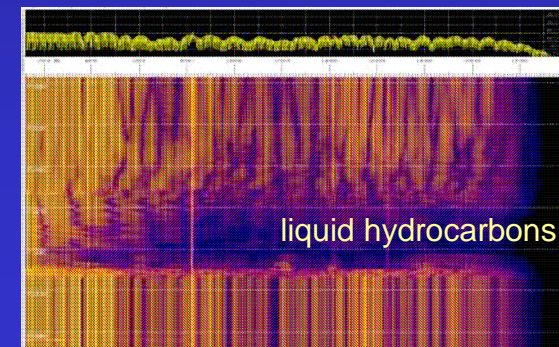

EKD in the mud line–enhancement II & Flow

Solid and Cutting Separator Control Unit & Acoustic Attenuation Spectroscope & Mud Flow Meter

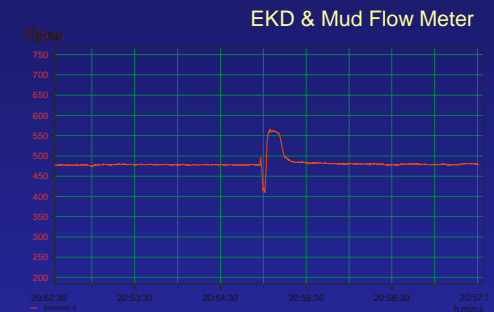
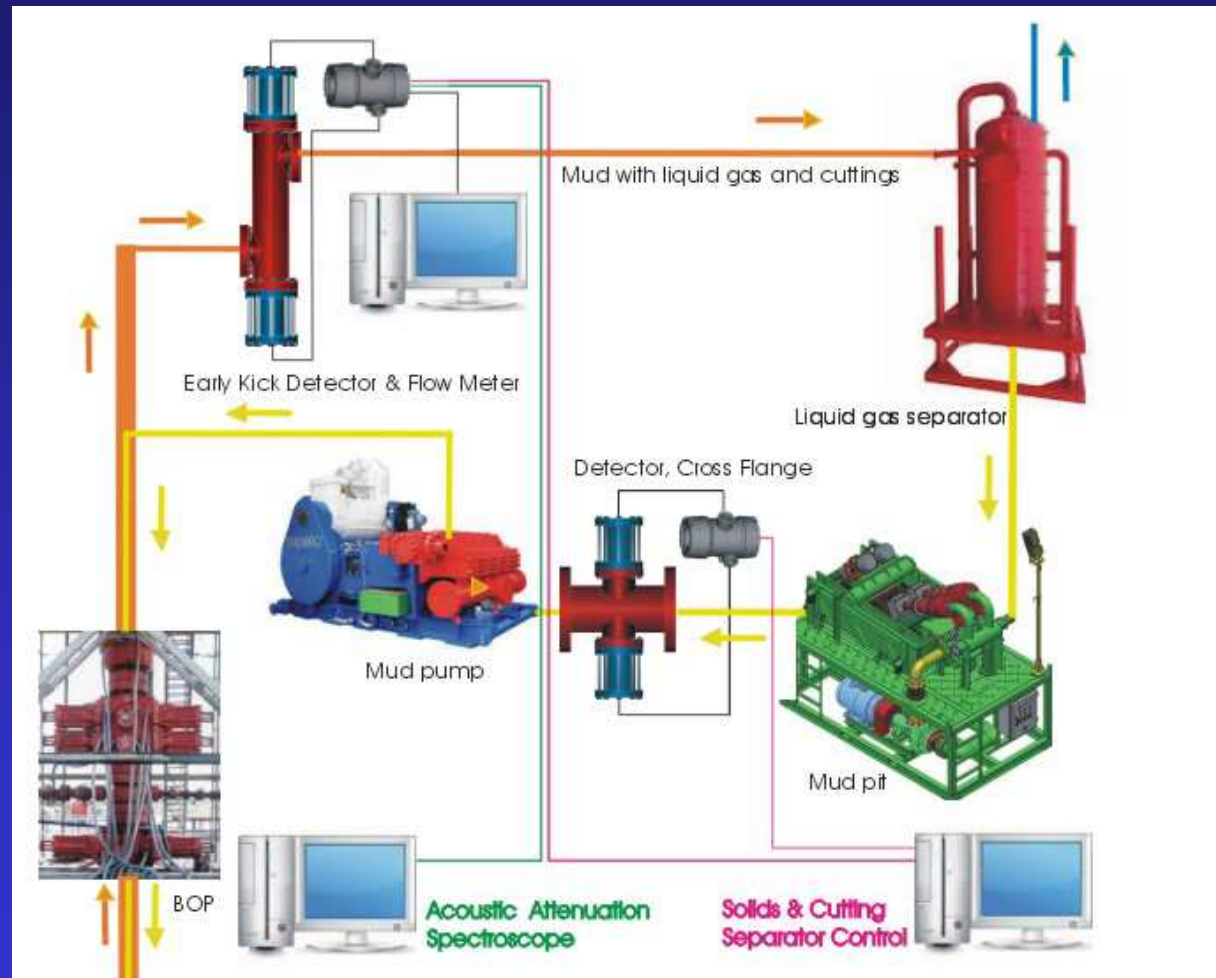

Solids &Cutting Separator Control Measurement

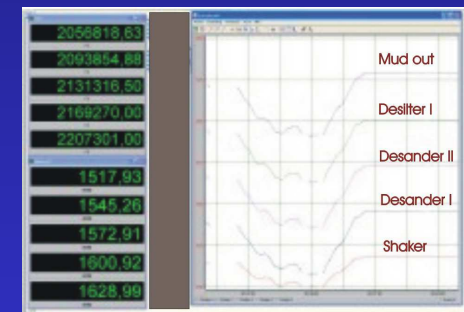

Acoustic Attenuation Spectroscope

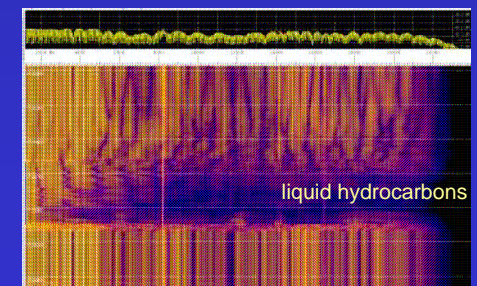

EKD & AAS in the closed loop mud line

Proposal for the integration of ultrasonic EKD in closed loop drilling of Weatherford

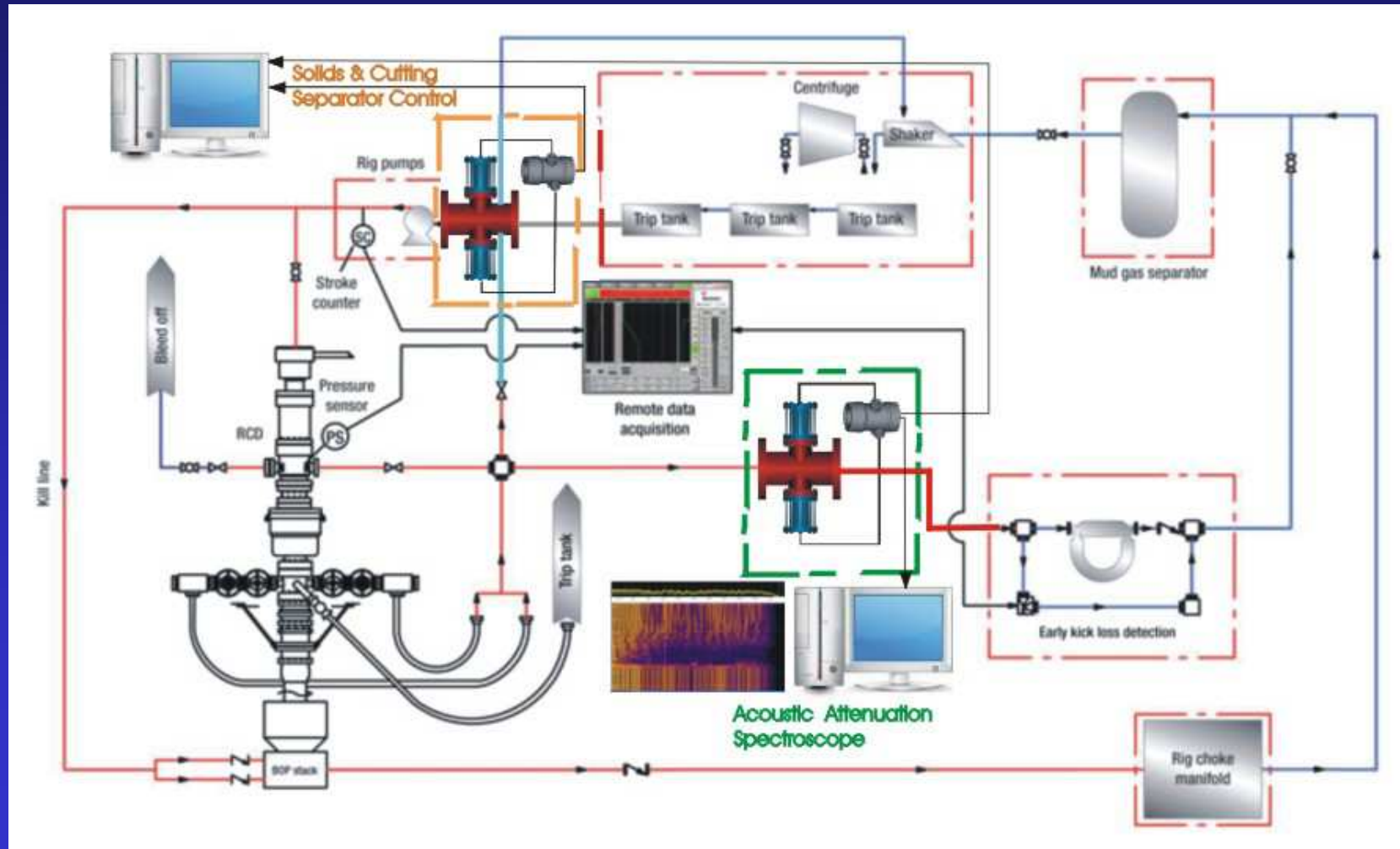

under use of original drawing of Weatherford International

Early Kick Detection-Variants for Installation

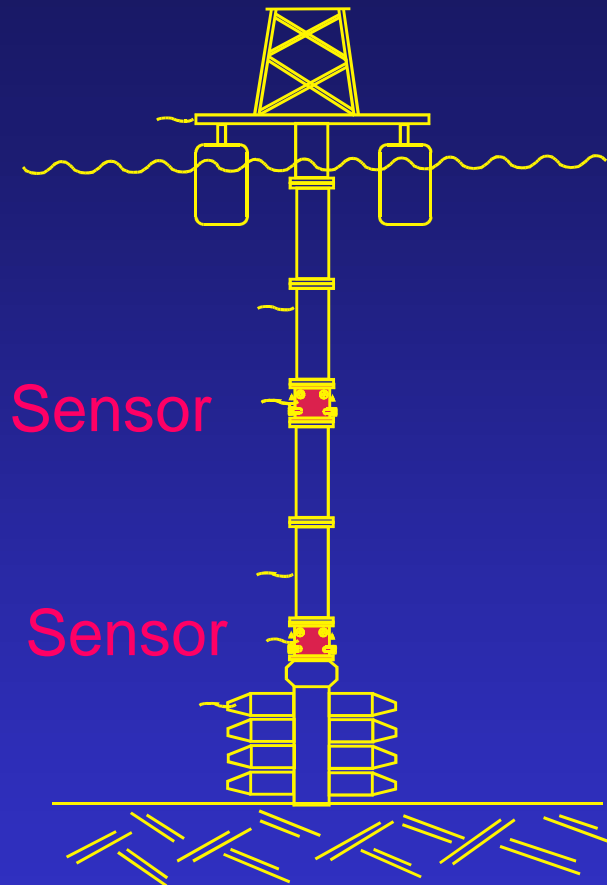

Fig. 5

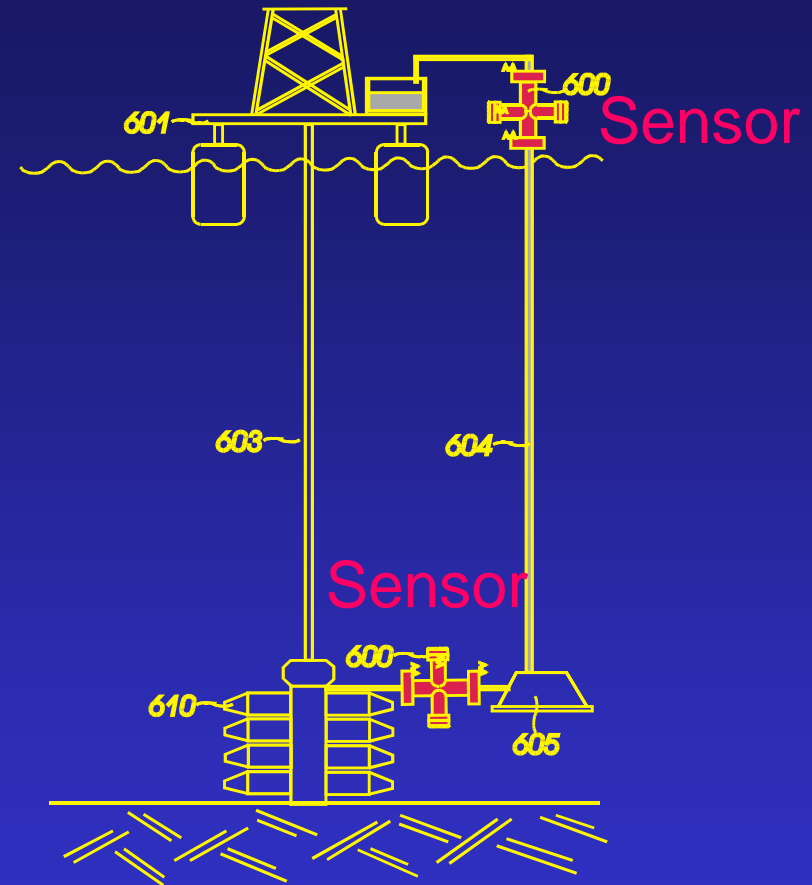
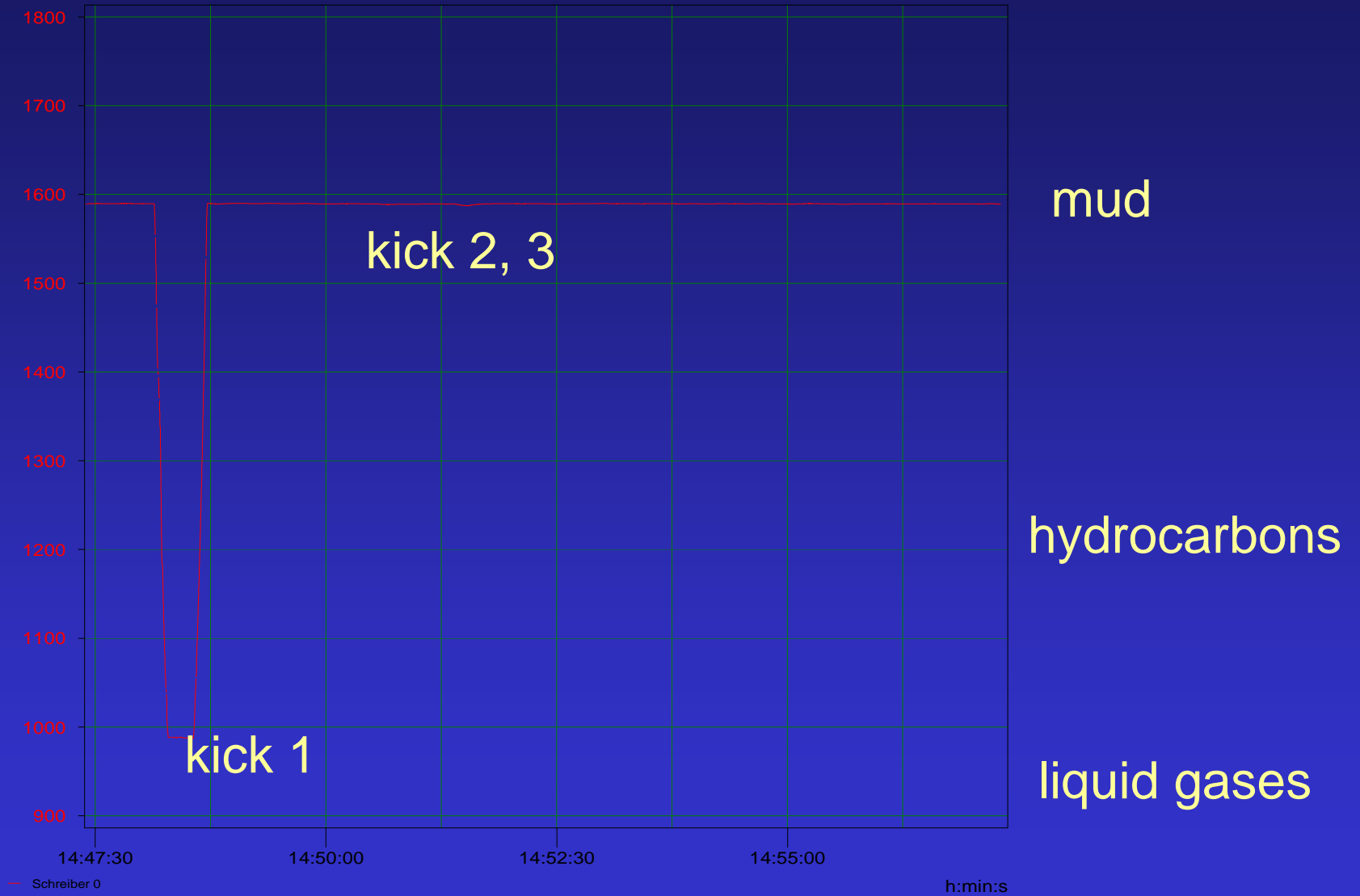

Fig. 6

Same sensors for all applications

Ultrasonic EKD System – exemple measurement of sonic speed I



Ultrasonic EKD System – exemple measurement of sonic speed II

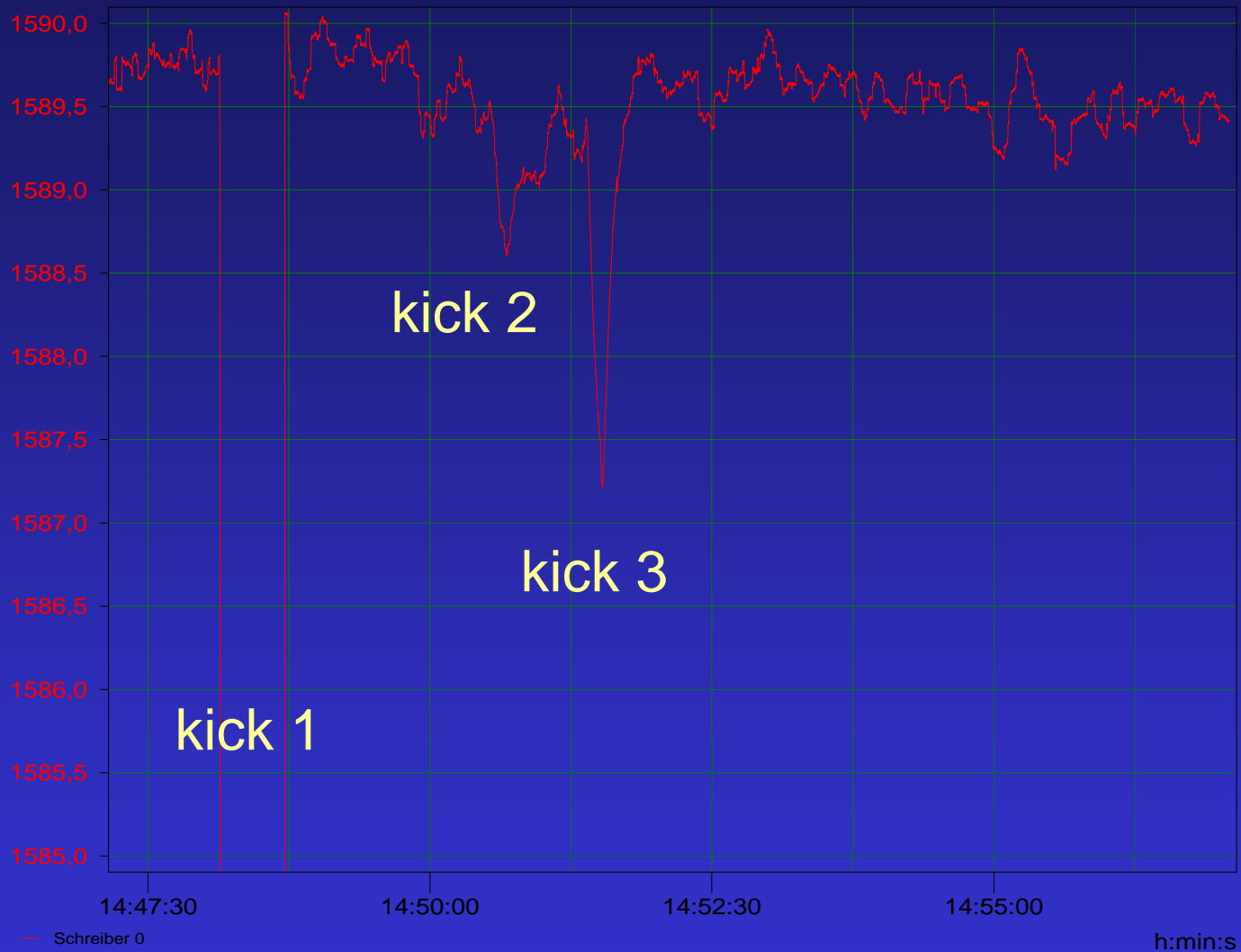

same situation - higher resolution

Ultrasonic EKD System – exemple measurement of attenuation

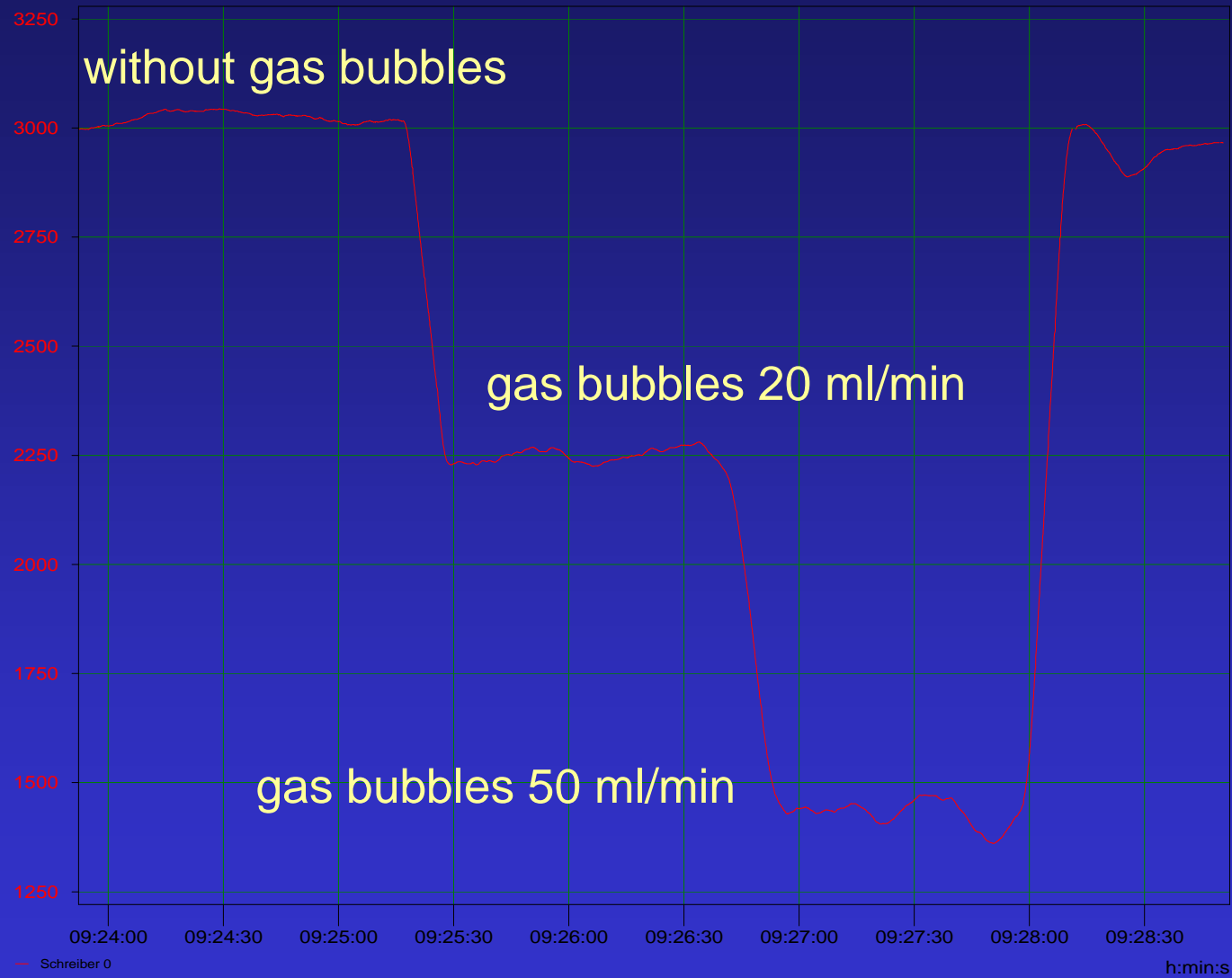

Early Kick Detection - Inline Installation

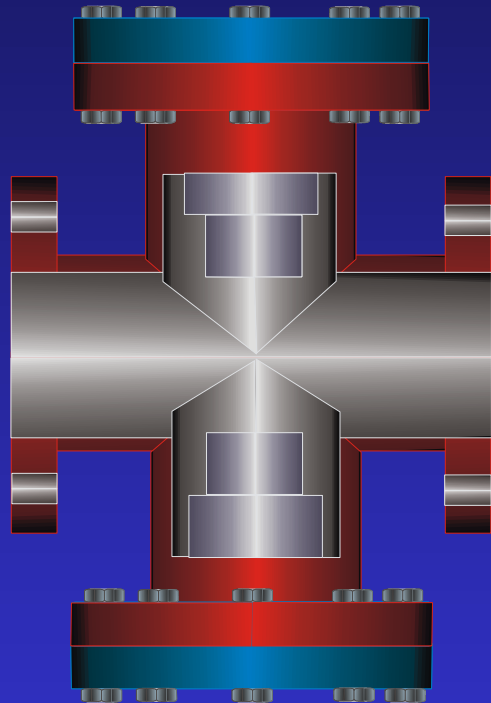

Sound path in high pressure fittings

For different applications, the ultrasonic sensors can be mounted in-line.

Exemple:

On customer sensor installed in:

Flanged Crosses
with API 6A



Studded Cross with integral
Flange design in accordance
with API 6A



Ultrasonic Early Kick Detection (EKD) System

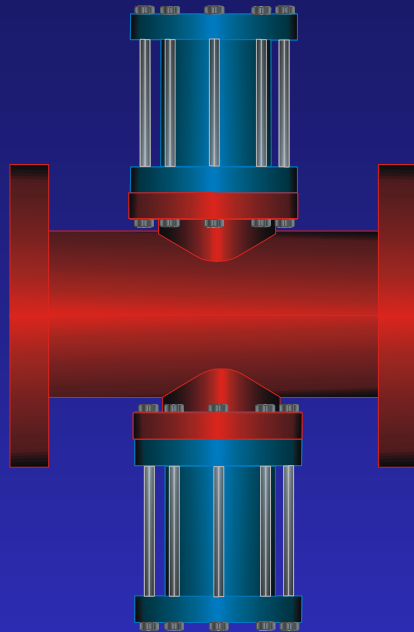

We manufacture EKD systems according to your applications.

Your inquiries about specific products for the measurement of EKD, Mud Solid Control or Solids Content in crude oil they should be directed to:

IBJ Technology
Frank-Michael Jäger

Colkwitzer Weg 7
04416 Markkleeberg
Germany

www.ibj-technology.com
fmj@ibj-technology.com

Tel.: +49 341 3380172